

TMUPS

Next Generation UPS for Business Critical Loads

From 100KW scalable upto 10.5MW



WWW.TMEIC.COM

TMUPS: Reliable, Energy efficient and Flexible UPS solution designed to deliver continuous power in most demanding environments with compact footprint and unprecedented load capabilities which delivers utmost flexibility to provide the ideal solution to customers.

With expert knowledge of energy conversion and rich legacy of parent companies **Toshiba** and **Mitsubishi-Electric** in the field of power electronics, TMEIC's strength in Design, Engineering, Manufacturing, Supply, Installation, Commissioning and Servicing brings immense value for our customers globally.



UPS Development History

50+ years of manufacturing experience and pioneering in cutting-edge inverter and converter technology



800+ Large UPS deployed on field

2008

CSTBT UPS

First to introduce the highest efficient UPS in the world with Double Conversion efficiency upto 96.5%
Smart Drive efficiency upto 98.5%



1991

IGBT UPS

First to introduce in the world



1982

TRANSISTOR UPS

CNV:SCR
INV:Transistor

1964

SCR UPS



CNV:SCR
INV:SCR

Next-generation UPS Solutions for Business-Critical Loads!

TMUPS Series Uninterruptible Power Supply (UPS) design with its patented conversion technology delivers the highest efficiency in the industry to go along with the quality and reliability that users are accustomed to when specifying TMUPS.

High
Efficiency
>98%*



Redundant Modular MW UPS

700kW~1.75MW

TMUPS MW series designed to deliver megawatt of power in a single UPS frame built with redundant scalable operation. The latest generation patented CSTBT power modules with multilevel power conversion technology enhances components life, improves reliability and efficiency. Customer can benefit with reduced total cost of ownership and improved PUE.

Features

- ▶ Scalable upto 6 units in parallel to meet the redundancy requirements
- ▶ Compact footprint design delivers more power density per sq.ft. in the industry
- ▶ Multi-level power conversion in both rectifier and inverter increases UPS life, reliability and availability
- ▶ Most suitable for High density Data center and large industrial applications
- ▶ Automatic input phase reversal detection and protection (Uninterrupted rectifier operation guaranteed)
- ▶ Compatible for 100% regenerative loads with bidirectional power converters
- ▶ Flexible Smart drive mode operation delivers very high efficiency even at lower load levels

Single Module UPSs

100kW~600kW

World's first multi-level conversion Uninterruptible Power Supply, TMUPS is the wise response from TMEIC for the growing demand of high reliability and efficient power solution for mission-critical applications.

Innovative multilevel power conversion with latest generation patented CSTBT power modules enhances components life, improves reliability and efficiency. Customer can benefit with reduced total cost of ownership and improved PUE.

Features

- ▶ Scalable upto 8 units in parallel to meet the redundancy requirements
- ▶ Compact footprint design delivers more power density per sq.ft. in the industry
- ▶ Multi-level power conversion in both rectifier and inverter increases UPS life, reliability and availability
- ▶ Compatible for 100% regenerative loads with bidirectional power converters
- ▶ Automatic input phase reversal detection and protection (Uninterrupted rectifier operation guaranteed)
- ▶ Flexible Smart drive mode operation delivers very high efficiency even at lower load levels

* Smart Drive Mode

Innovative Multilevel Power Conversion Technology

State-of-the-art multilevel technology in both rectifier and inverter creates multiple voltage levels to reduce voltage and thermal stress on components. With this design components life, reliability and availability is increased significantly with proven track record of more than a decade.

Benefits

- ▶ Lower voltage stress on power semi-conductors devices
- ▶ Significant reduction of noise and electromagnetic interference
- ▶ Higher efficiency (lower losses)
- ▶ Higher system reliability and compactness

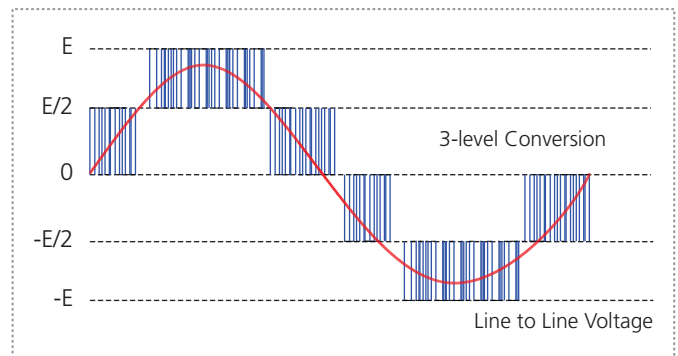
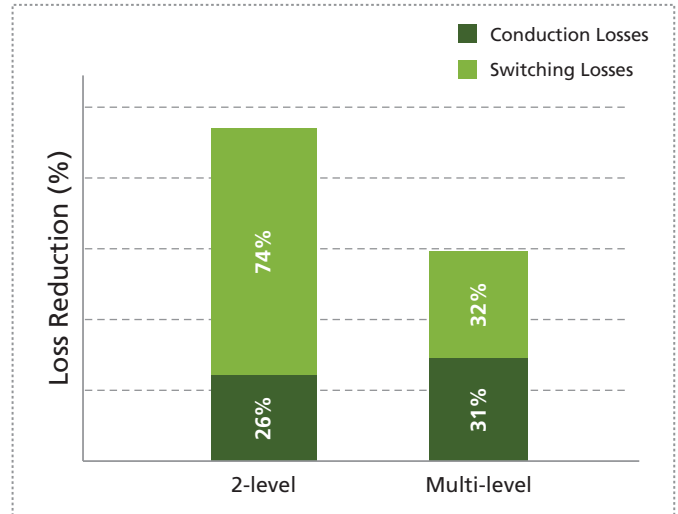
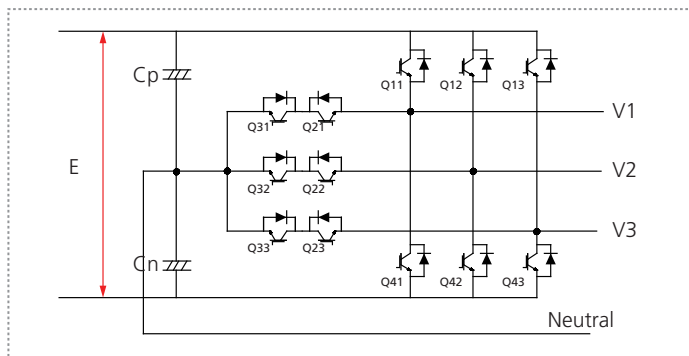

Voltage variation Δv at the terminals
 E @Two-level, $E/2$ @Three-level
 Reduction of conversion loss, reduced EMI interference, reduction of harmonics and reactor size.

Robust & Proprietary Power Module

CSTBT is fabricated using a special vertical structure to improve carrier concentration and lowering saturation losses.

- ▶ Robust in design
- ▶ High endurance in dynamic load conditions
- ▶ High thermal stability delivering continuous power in most demanding environments
- ▶ Reduced losses

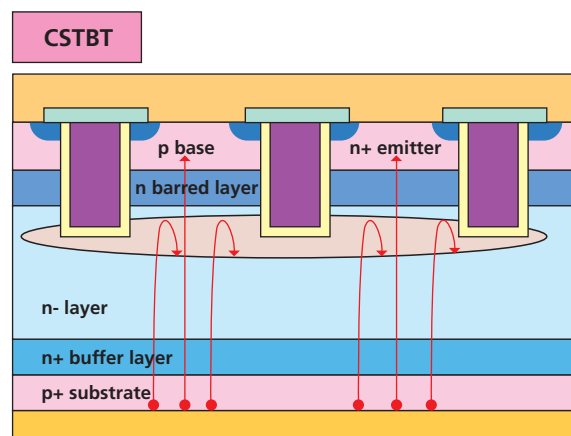

Advanced Control System for Optimum Performance

Power semiconductors are used universally in power conversion however the key difference is how the control circuit delivers high performance. TMUPS uses MITSUBISHI CSTBT with its unique and advanced control circuit to deliver unparalleled performance.

Features

- ▶ 3-phase independent control (100% unbalanced loads)
- ▶ Feed forward control design delivers excellent dynamic response to step load changes in parallel operation
- ▶ Compatible with regenerative loads (reverse power flow)
- ▶ High speed controller supports highly reliable multi-module system upto 8 UPSs
- ▶ Instantaneous Wave Form Control for both input current and output voltage

Performance

- ▶ Reduced output voltage fluctuation
- ▶ Reduced output voltage distortion
- ▶ Unbalanced load capability
- ▶ Eliminate input current harmonics
- ▶ Self diagnostic function

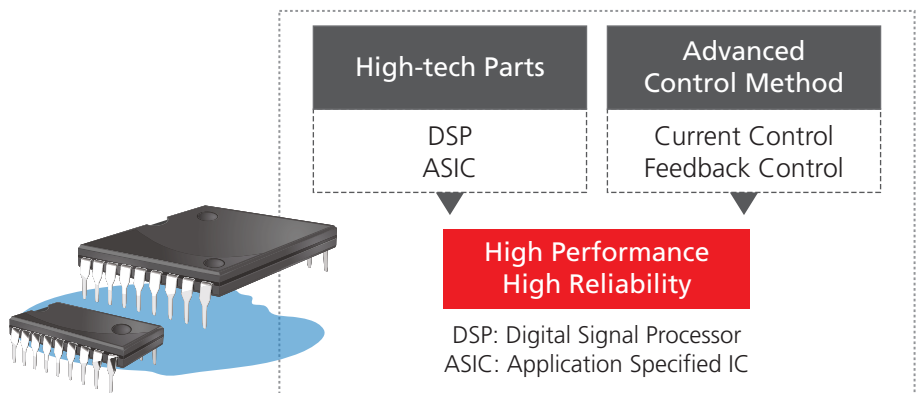

UPS System Flexibility

The TMUPS Multi-Module System (MMS) configuration incorporates individual parallel control and static bypass circuitry in each independent UPS frame.

Thus, TMUPS MMS Configuration offers complete system redundancy, reliability, flexibility with cost saving scalability and reduced footprint.

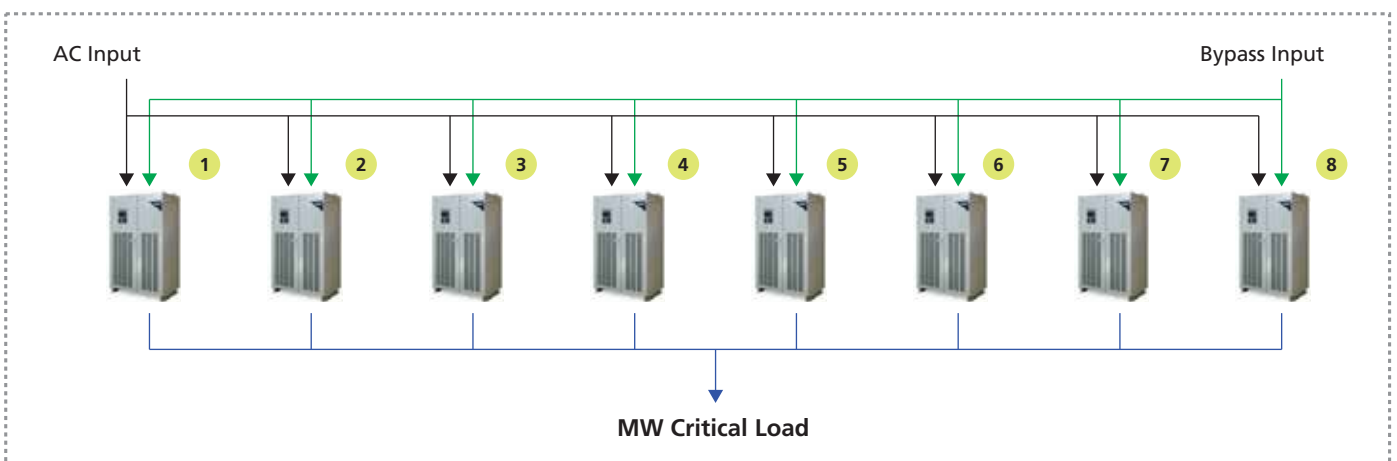

Benefits

- ▶ MMS Capacity: Expandable and to protect upto 10.5MW
- ▶ Cross current sensor less control
- ▶ Instantaneous equal load sharing with current minor loop control
- ▶ Individual UPS modules can be added or isolated for expansion or maintenance

Highest Efficiency

TMEIC UPS is the most efficient true online double-conversion UPS at all load levels. Unique combination of multilevel conversion technology with CSTBT structure differentiates TMUPS in terms of higher efficiency translates into energy savings.

This benefits the user with reduced cost of ownership and improved Power Usage Effectiveness (PUE).

Benefits

- ▶ Capex & Opex savings in cooling cost
- ▶ Energy savings and reduced TCO
- ▶ Space savings

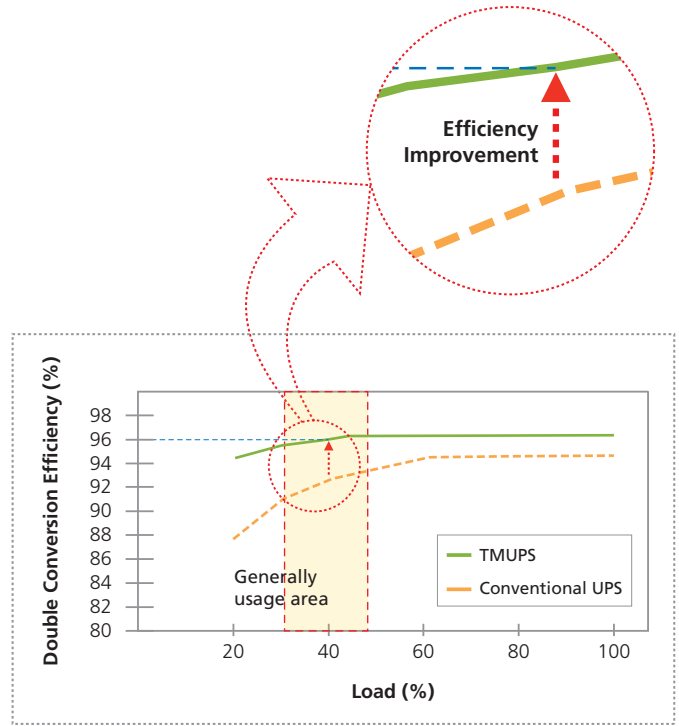

TMUPS Smart Drive Mode of Operation

TMUPS provides flexibility to choose Smart drive mode to increase the power conversion efficiency and reduce the operational energy costs. In Smart drive mode of operation, the load is supplied by static bypass and the inverter is working in parallel with bypass for power factor compensation and harmonic correction.

Benefits

- ▶ High Efficiency
- ▶ Significant reduction in OPEX
- ▶ No compromise on battery health
- ▶ Active PF correction – Reduced demand from grid
- ▶ Harmonic compensation

More importantly, TMUPS Smart drive mode uses rectifier only to charge the batteries and inverter for power conditioning.

This ensures battery is not discharged or cycled frequently when the grid power conditions are not reliable, to improve battery life and safety.

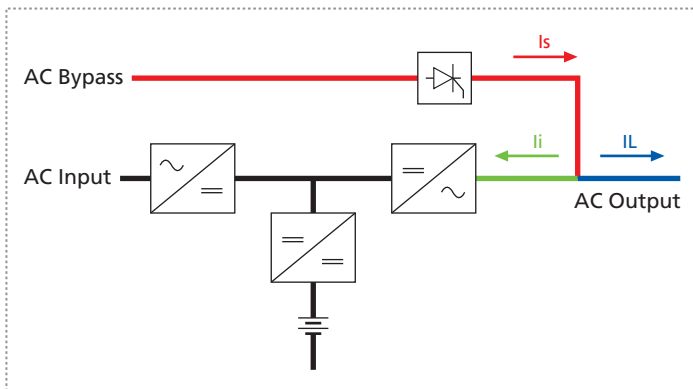
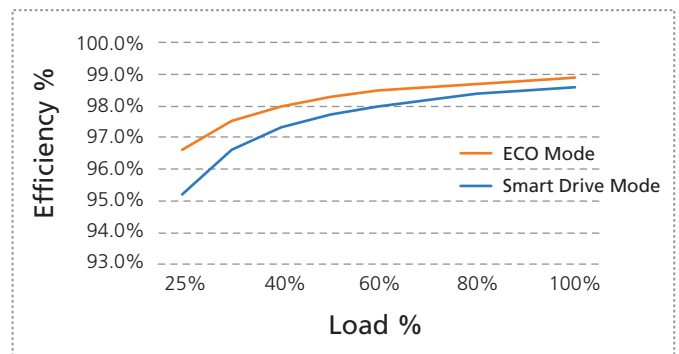

Smart Drive Mode of Operation

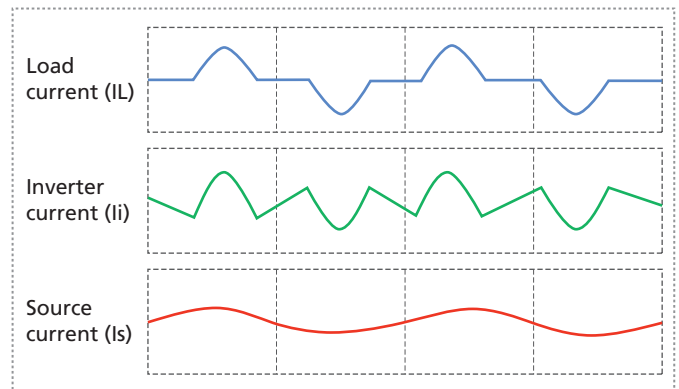

Smart Drive Active Power Compensation

* Graph not to scale

TMUPS MW Series

Redundant modular UPS for large data center needs!

TMUPS MW series is especially designed to meet the growing demand of megawatt UPSs in high power density Data Centers. With its compact footprint and parallel redundant modular flexibility with highest reliability & efficiency, TMUPS MW series makes a difference and provides low cost of ownership.

TMUPS design with larger capacity modules in one frame reduces the cost of cable infrastructure and complexity of distribution.

UPS Module

- ▶ Power converter unit
- ▶ Independent main control circuit
- ▶ Parallel upto six UPSs

Common Bypass Module

- ▶ Static transfer switch
- ▶ Main control unit
- ▶ LCD touch panel
- ▶ Cable entry (Top / Bottom)

Electrical

- ▶ 415 VAC 3Ph 3W
- ▶ Input THDI <3%
- ▶ Input PF >0.99
- ▶ Feed forward and advanced current minor loop control
- ▶ Built-in modular SPD

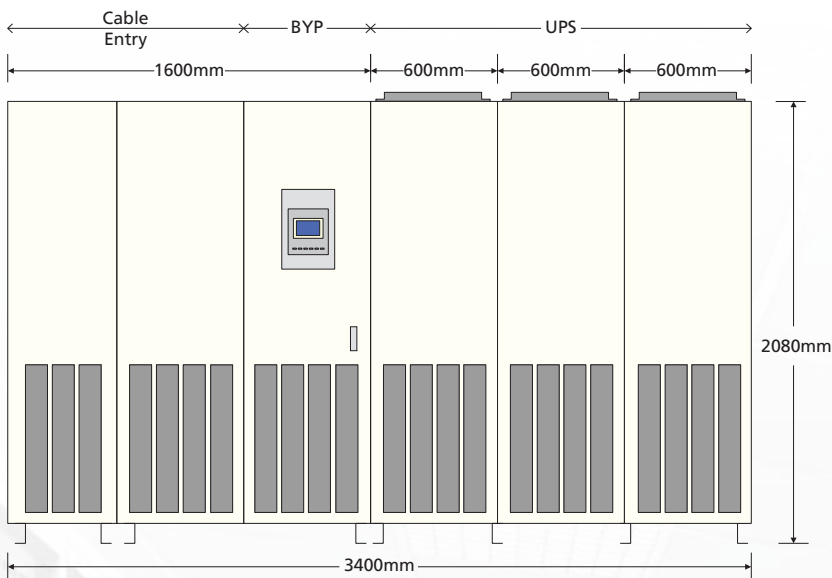

Capacity 1.05 MW UPS Footprint

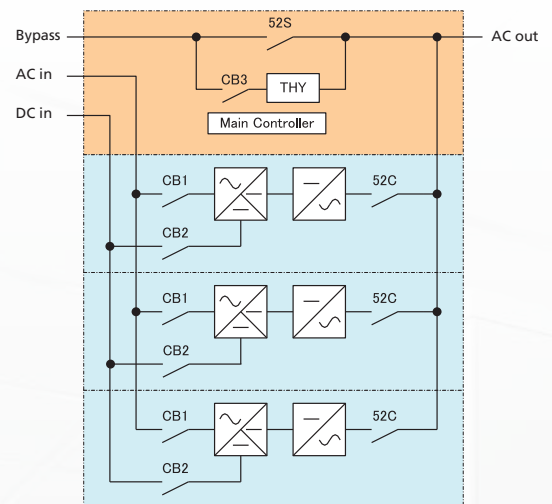

Adaptability and Scalability

With TMUPS MW series Parallel Redundant modular systems architecture, UPS modules can be added or removed as per the load requirements.

This engineered-in flexibility makes the TMUPS MW series system design an economical alternative in an unpredictable world.

Open Architecture Communication

TMUPS MW series UPS provides the flexibility to communicate on wide range of communication protocols, for easy and effective maintenance.

Superior Performance

By controlling the proprietary CSTBT in our UPS's inverter and converter section, we can achieve unparalleled step load performance.

Our advanced control algorithm promotes highspeed fault detection and control.

Technical Specifications

DESCRIPTION	TMUPS W250 Series							
Rating (kVA)	100	120	160	200	300	400	500	600
Design Topology	Online double conversion (VFI-SS-III), Transformerless design							
Regulatory	Safety : IEC 62040 -1, EMC : IEC 62040 -2, Performance : IEC 62040 -3							
Power Expansion	Upto 8 units with advanced current mirror loop control for reliable parallel operation							
Surge Protection	Built-in modular type II surge protection							
Emergency Power off (EPO)	Available in front panel							
Cable Entry ¹	Bottom							
Protection Class	IEC-IP-20							
Colour	Grey RAL 7032							
Input Characteristics								
Converter Technology	Robust CSTBT based multi-level Technology, High Efficiency & Long life							
Nominal Voltage	3Phase 380/400/415 V + PE							
Voltage Tolerance	+15%, -20%							
Frequency	50 Hz \pm 10%							
Power Factor	0.99							
Current Distortion (THDi) @ Rated Load ²	3%							
System Power Walk in	30 secs programmable and up to 3600 secs programmable converter start delay							
Output Characteristics								
Inverter Technology	Robust CSTBT based multi-level Technology, High Efficiency & Long Life							
Nominal Voltage	3Phase-4 Wire 400/415 V (selectable)							
Frequency	50 Hz							
Frequency Sync Range	\pm 1% to \pm 5% (Selectable in 1% increment)							
Frequency Slew Rate	1 Hz/sec to 5 Hz/sec (Selectable in 1 Hz/sec increment)							
Phase Displacement	\pm 1 Deg @ 100% balanced load, \pm 3 Deg @ 100% unbalanced load							
Power Factor	Unity							
Voltage Regulation Static Load	< 1%							
Dynamic Response (100% Step Load)	< 2%, recovery within 20ms							
Voltage Distortion (THDv) @ Rated Load	< 2% Linear load, < 3% Non-linear load							
Over Load	110% for 60 Minutes, 125% for 10 Minutes, 150% for 1 Minute							
Bypass Characteristics								
Nominal Voltage	3 Phase - 4wire 400/415V +/-10%							
Nominal Frequency	50Hz							
Short Circuit withstand Capacity	500% for 20ms							
Ecomode with PF & Harmonics Correction	Available as a value-added optional feature (Smart Drive)							
Battery								
Nominal Voltage	480 VDC (Flexible)							
Max DC Voltage Protection	Upto 700 VDC							
Battery Type	VRLA, Flooded, Ni-Cd, LIB							
Efficiency								
Double Conversion Mode	Upto 96.5%							
Smart Drive Mode (Optional Feature)	Upto 98.5%, Upto 99% Eco mode							
Communication								
Intelligent Monitoring (Option)	Modbus/TCP, Modbus/RS485, RS 232, SNMP							
UPS Display	Graphical Touchscreen with LCD Display							
Alarm and Status Information	Through LCD Display, user programmable input and output dry contacts							
Environmental Conditions								
Operating Temperature ⁴	0 to 40° C							
Relative Humidity	5 to 95% non-condensing							
Operating Altitude	1000m above MSL without derating							
Physical								
Dimension (W x D x H) ³	700 x 832 x 2080	700 x 832 x 2080	1400 x 832 x 2080	1600 x 832 x 2080				
Weight (kg)	550	550	610	610	990	1100	1590	1650

Specifications are subject to change without prior notice as part of continuous development.
 1 - Top entry optional on request 2 - With source THDv < 1% 3 - Dimension tolerance \pm 10 mm 4 - As per maintenance guidelines detailed in user manual

Technical Specifications

DESCRIPTION	TMUPS W350 Series			
Rating (kVA / kW)	700/700	1050/1050	1400/1400	1750/1750
Design Topology	Online double conversion (VFI-SS-III), Transformerless Design			
Regulatory	Safety : IEC 62040 -1, EMC : IEC 62040 -2, Performance : IEC 62040 -3			
Power Expansion	Upto 6 units, 10.5 MW- with advanced current minor loop control for reliable parallel operation			
Surge Protection	Built-in modular type II surge protection			
Emergency Power off (EPO)	Available in front panel			
Cable Entry	Top & Bottom as standard			
Protection Class	IP-20			
Colour	Grey RAL 7032			
Input Characteristics				
Converter Technology	Robust CSTBT based multi-level Technology, High Efficiency & Long life			
Nominal Voltage	3Phase 380/400/415 V + PE			
Voltage Tolerance	+15%, -20%			
Frequency	50 Hz \pm 10%			
Power Factor	0.99			
Current Distortion (THDi) @ Rated Load ¹	3%			
System Power Walk in	30 secs programmable and up to 3600 secs programmable converter start delay			
Output Characteristics				
Inverter Technology	Robust CSTBT based multi-level Technology, High Efficiency & Long Life			
Nominal Voltage	3Phase-4 Wire 400/415 V (selectable)			
Frequency	50 Hz			
Frequency Sync Range	\pm 1% to \pm 5% (Selectable in 1% increment)			
Frequency Slew Rate	1 Hz/sec to 5 Hz/sec (Selectable in 1 Hz/sec increment)			
Phase Displacement	\pm 1 Deg @ 100% balanced load, \pm 3 Deg @ 100% unbalanced load			
Power Factor	Unity			
Voltage Regulation Static Load	< 1%			
Dynamic Response (100% Step Load)	< 2%, recovery within 20ms			
Voltage Distortion (THDv) @ Rated Load	<2% Linear load, <3% Non-linear load			
Over Load	110% for 60 Minutes, 125% for 10 Minutes, 150% for 1 Minute			
Bypass Characteristics				
Nominal Voltage	3 Phase - 4wire 400/415V +/-10%			
Nominal Frequency	50Hz			
Short Circuit withstand Capacity	500% for 20ms			
Backfeed Protection	Available			
Ecomode with PF & Harmonics Correction	Available as a value-added optional feature (Smart drive)			
Battery				
Nominal Voltage	480 VDC (Flexible)			
Max DC Voltage Protection	Upto 700 VDC			
Battery Type	VRLA, Flooded, Ni-Cd, LIB			
Decentralized Battery Bank Option	Available			
Efficiency				
Double Conversion Mode ²	Upto 97%			
Smart Drive Mode (Optional Feature)	Upto 98.5%, Upto 99% Eco Mode			
Communication				
Intelligent Monitoring (Option)	Modbus/TCP, Modbus/RS485, RS 232, SNMP			
UPS Display	Graphical Touchscreen with LCD Display			
Alarm and Status Information	Through LCD Display, user programmable input and output dry contacts			
Environmental Conditions				
Operating Temperature ⁴	0 to 40° C			
Relative Humidity	5 to 95% non-condensing			
Operating Altitude	1000m above MSL without derating			
Physical				
Dimension (W x D x H) ³	2800 x 900 x 2080	3400 x 900 x 2080	4300 x 900 x 2080	4900 x 900 x 2080
Weight (kg)	2600	3400	4480	5300

Specifications are subject to change without prior notice as part of continuous development.
1 - With source THDv < 1% 2 - 3 Wire 3 - Dimension tolerance \pm 10 mm 4 - As per maintenance guidelines detailed in user manual

Applications

DATA CENTERS



BANKING AND COMMERCIAL



Our patented technologies provide a true online UPS that offer High Reliability & Highest Efficiency, No matter what is the load!



HEALTHCARE



INDUSTRIAL

UPS Life Cycle Support

Supervision & Commissioning Services

The maintenance needs of TMEIC UPS are minimal but crucial. TMEIC provides appropriate service support meeting the budget while maximizing the performance and life of your TMEIC UPSs with its factory trained engineering team.

The field engineers are trained at our factory through on:

- ▶ Product design know-how
- ▶ Time saving commissioning
- ▶ Site acceptance test
- ▶ Trouble shooting and root cause analysis

This approach helps us to avoid changes & modifications at project sites which in turn enables quick start-up of critical loads and keeping the load uptime.



TMUPS Service Care

The tailored, site-specific service agreements for simple guidance on preventive maintenance with agreed response time, 24 x 7 x 365 coverage and replacement parts at discounted pricing.

TMUPS Service Plus

The periodic inspection & maintenance by TMEIC service team that includes calibration, and adjustment of UPS's control and monitoring systems to ensure continued performance and highest availability of UPS System.

Response time of 24 x 7 x 365 coverage, guaranteed load uptime with replacement spares parts including labour.

Training

TMEIC offers a variety of training opportunities including specialized customer hands on operation & maintenance training at our factory or at site.

TMEIC Remote Diagnostics Services

TMEIC's system diagnostics 'TRACE' tool can bring UPS status in detail at the engineer's remote view enabling a quick path to problem resolution. System faults are automatically identified for quick root cause analysis and preventive actions. TMEIC service engineers at our various offices / service stations, can analyze the data and provide steps for resolution.

TMEIC service engineers with factories, offices and spare parts depots across the globe.



3000+ Employees
Worldwide



24 x 7 x 365 Support
Toll Free no.
1800 1234 292



Remote
Diagnostics



Spare Parts
Depots
Worldwide



300+ Service
Engineers
Worldwide



TMEIC Post-Sales
Customer Support
Network

TMEIC Innovative Product Solutions

PV Inverters

We manufacture and supply advanced, energy-efficient, sustainable and reliable 3-level PV inverters. TMEIC's Inverters deliver high energy efficiency (99%), lower switching losses by 56%, lower equipment footprint and weight thus leading to unparalleled yield on customer investment.

- ▶ Premium efficiency = 99%
- ▶ Large capacity & wide MPPT model (2.5MW/2.5MVA)
- ▶ World leader for compact size (1.4MVA/m²)
- ▶ No de-rating up to 50°C
- ▶ Built-in Night-time Var Injection (24hrs operation is also possible)
- ▶ Negative grounding kit with optimal insulation monitoring
- ▶ Less number of components & high reliability

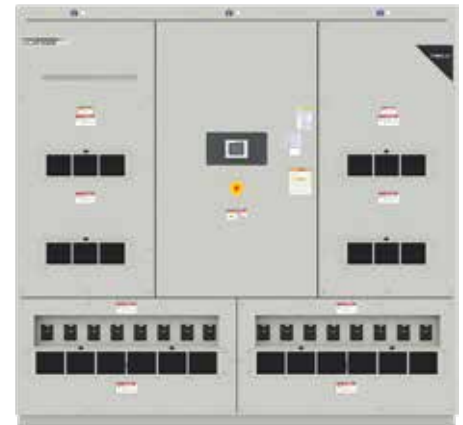

TMdrive MV Variable Frequency Drives (VFDs)

TMdrive-MVe2 & TMdrive-MVG2 are Medium Voltage, Variable Frequency AC Drive System with multi-level near Sine Wave Output are suitable for applications using standard Induction and Synchronous Motors.



- ▶ Power rating 200KVA-19500KVA
- ▶ Voltage class 3.3KV-11KV
- ▶ High efficiency: 97%
- ▶ Premium Power Factor: >0.99
- ▶ Harmonics less than 2%
- ▶ Reactive Power Compensation
- ▶ Regenerative feature: Higher energy saving
- ▶ Motor-friendly wave form
- ▶ High MTBF means less failures & high uptime
- ▶ Modular construction resulting to low MTTR

Squirrel Cage Induction Motors

From Design to Quality Control - All made the TMEIC Way

Motors designed & manufactured in our factory in India, strictly in accordance with TMEIC Japan processes & practices, comply to Indian & international standards and bring unmatched value to our customers.

- ▶ IEC Frame size: 315-900
- ▶ Power rating: 160-23000kW
- ▶ Voltage class: 380V-13.8kV
- ▶ Enclosure: TEFC / TEAAC / TEWAC / WPII
- ▶ Certifications: Baseefa, CSA, CCOE
- ▶ Combined testing of Motors & Drives
- ▶ High power to weight ratio - Smaller footprint
- ▶ Ease of operation & maintenance
- ▶ Rugged construction to suit demanding application
- ▶ Suitable for severe corrosive & hazardous environment
- ▶ Maximum uptime for high return of investment
- ▶ Designed for Inverter Duty Applications – TMEIC Make Motor & Drive for better performance



Built on the proud history of **Toshiba** and **Mitsubishi Electric**, TMEIC continues their legacy of providing high performance and high power solutions to customers around the world.

TOSHIBA

(TOSHIBA CORPORATION)
established in **1896**
Tokyo Electric Co. Ltd.



mitsubishi

(MITSUBISHI ELECTRIC)
established in **1921**
Mitsubishi Electric Corporation

ROTATING MACHINES, POWER ELECTRONICS & INDUSTRIAL SYSTEMS DEPARTMENTS

TMEiC

(TOSHIBA MITSUBISHI ELECTRIC INDUSTRIAL SYSTEMS CORPORATION)
established in **2003**

TMEIC is a world-class leader in industrial systems integration, contributing to production technology and management of the environment with cutting-edge technology.

As an industrial system integrator, we are focused on the future of 'industry', 'society' and 'environment' in order to respond to the on-site needs of production and to facilitate the harmonization of social development & beautiful global environment.

Our core technologies lie in the power electronics which transforms and controls the required electric power, and the engineering that extends from planning to operations of the plant as a whole. Our cutting-edge technology in these core areas contributes to production and environment management.

'We are TMEIC. We Drive Industry.'

Global Presence

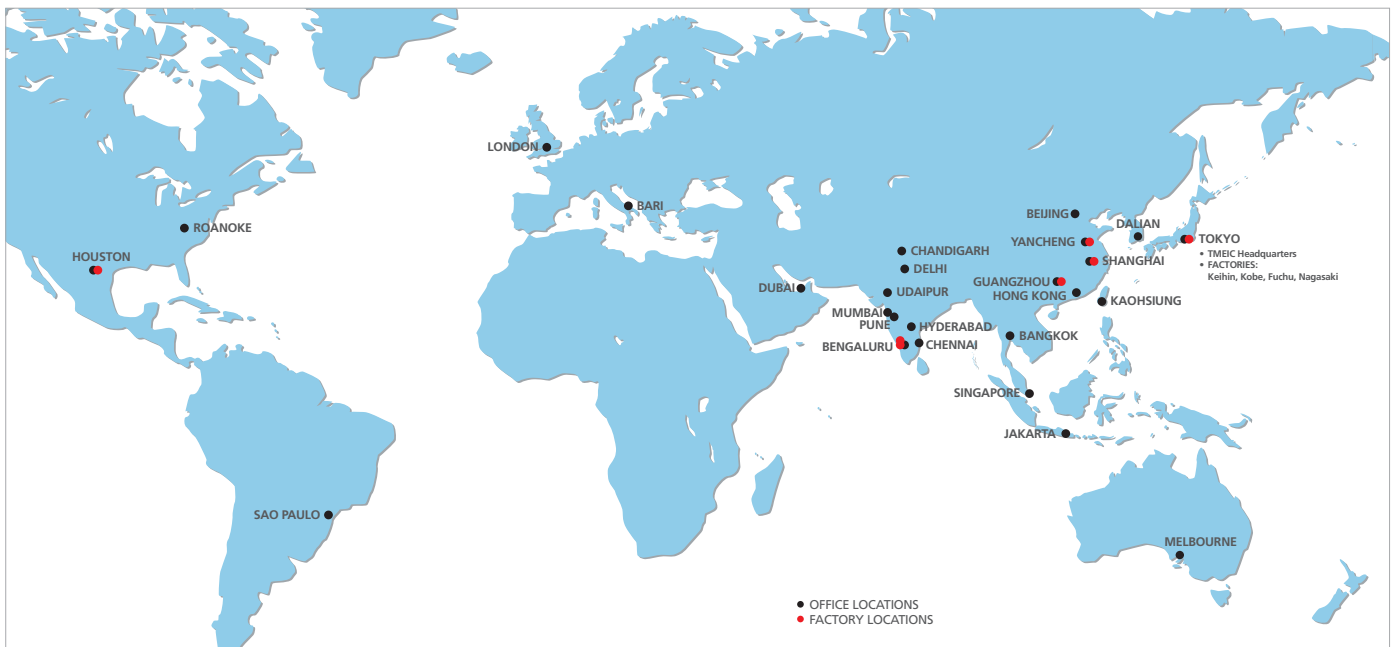

Manufacturing Facility



▲ Rotating Machine Factory & Power Electronics Factory (Tumakuru, Near Bengaluru)

50+ years of manufacturing experience

in pioneering cutting-edge inverter and converter technology allows us to deliver our customers the best performing, energy-efficient and the most reliable products.

Our world-class manufacturing plant has the state-of-the-art production, testing facility, quality, SCM capabilities and products that meet IEC standards.

We have well trained employees having expertise in development of PV inverters, UPS systems and MV motors & drives.

It is our endeavour to bring full capabilities of our Japanese operations to India as we take on the new challenge of building a better tomorrow for India.



▲ Assembly Line



▲ Test Bench



TMEIC Industrial Systems India Private Limited

Corporate Office:

The Millenia, Tower A, 10th Floor, #1 & 2, Murphy Road,
Halasuru, Bengaluru 560 008. India.
Tel.: +91 80 675 15599

Registered Office:

Unit #03-01, Third Floor, Block 2, Cyber Pearl, HITEC City,
Madhapur, Hyderabad 500 081. India.
Tel.: +91 40 443 40000

Branch Offices:

MUMBAI:

13th Floor, B Wing, 247 Park,
Lal Bahadur Shastri Road,
Gandhi Nagar, Hindustan C,
Vikhroli (W), Mumbai 400 079. India.

PUNE:

Regus-'Sky One' Building,
Unit Nos.101-104, 1st Floor,
Kalyani Nagar, Pune 411 006. India.
Tel.: +91-20-6790-5700

DELHI / GURGAON:

S-12, Vatika Business Centre,
Vatika Triangle 2nd Floor,
Sushant Lok Phase-I, Block-A,
M.G. Road, Gurgaon 122 002,
Haryana. India.
Tel.: +91-124-403-4966
Fax: +91-124-403-4966 Ext. 115

CHENNAI:

Plot No. 10, Bristol IT Park,
4th Floor, Office No. 407,
Thiru. Vi. Ka. Industrial Estate,
Guindy, Chennai 600 032. India.
Tel.: +91-44-4004-0619

Manufacturing Plant:

TUMAKURU:

Plot #316, Vasanthnarsapura Industrial Area, Phase 2,
Yaladadlu Village, Kora Hobli,
Tumakuru District - 572128. India.
Tel.: +91 8162 294 040

Enquiry: tmups@tmeic.in

URL: www.tmeic.com



24 x 7 x 365

Customer Service Support: +91-40-4434-0123

Toll Free No.: 1800 1234 292

E-mail: support.india@tmeic.in



TMEIC is a registered trademark of Toshiba Mitsubishi-Electric Industrial Systems Corporation.

All other products mentioned are registered trademarks and/or trademarks of their respective companies.

All specifications in this document are subject to change without notice. The above brochure is provided free of charge and without obligation to the reader or to TMEIC.

TMEIC does not accept, not imply, the acceptance of any liability with regard to the use of the information provided. TMEIC provides the information included herein as is and without warranty of any kind, express or implied, including but not limited to any implied statutory warranty of merchantability or fitness for particular purposes. The information is provided solely as a general reference to the potential benefits that may be attributable to the technology discussed. Individual results may vary. Independent analysis and testing of each application is required to determine the results and benefits to be achieved from the technology discussed. If you have any questions regarding your project requirements, please contact TMEIC India.

@2023 Toshiba Mitsubishi-Electric Industrial Systems Corporation, India

All Rights Reserved.